

Centre Number	Candidate Number	Name
---------------	------------------	------

UNIVERSITY OF CAMBRIDGE INTERNATIONAL EXAMINATIONS
International General Certificate of Secondary Education

COMBINED SCIENCE

0653/02

Paper 2

October/November 2004

1 hour 15 minutes

Candidates answer on the Question Paper.
No Additional Materials are required.

READ THESE INSTRUCTIONS FIRST

Write your Centre number, candidate number and name on all the work you hand in.
Write in dark blue or black pen in the spaces provided on the Question Paper.
You may use a soft pencil for any diagrams, graphs, tables or rough working.
Do not use staples, paper clips, highlighters, glue or correction fluid.

Answer **all** questions.
The number of marks is given in brackets [] at the end of each question or part question.
A copy of the Periodic Table is printed on page 20.

For Examiner's Use	
1	
2	
3	
4	
5	
6	
7	
8	
9	

If you have been given a label, look at the details. If any details are incorrect or missing, please fill in your correct details in the space given at the top of this page.

Stick your personal label here, if provided.

1 (a) Blood contains red cells, white cells and platelets.

(i) Describe how you can recognise red blood cells, apart from their colour, if you are looking at a blood sample using a microscope.

.....
.....[1]

(ii) What is the function of platelets?

.....[1]

(b) Fig. 1.1 is an outline of the human double circulatory system.

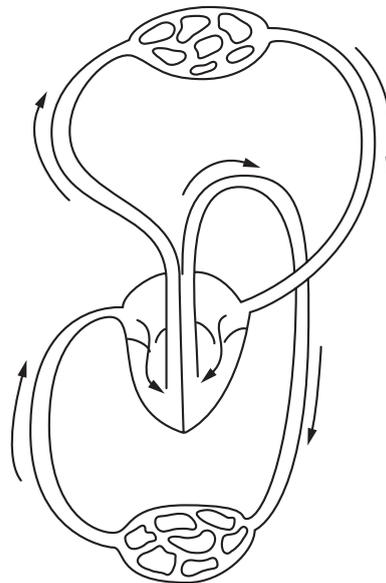

Fig. 1.1

(i) On the diagram,
write the letter **O** where the blood becomes oxygenated;
write the letter **A** on a vein which carries deoxygenated blood. [2]

(ii) The oxygenated blood goes back to the heart before it travels to the other parts of the body. Suggest why this is an advantage to the body.

.....
.....
.....[2]

- (iii) People who smoke cigarettes take carbon monoxide into their lungs. The carbon monoxide diffuses into their blood and combines with haemoglobin inside the red blood cells.

Explain why this can be harmful to a person's health.

.....

.....

.....[2]

- 2 Petroleum (crude oil) is processed to make a very large number of important products. Table 2.1 shows information about some of the fractions obtained from petroleum during the process of fractional distillation.

Table 2.1

fraction	boiling range /°C	number of carbon atoms per molecule
petroleum gas	less than 20	1 to 4
gasoline	70 to 120	5 to 10
kerosene	120 to 170	10 to 16

- (a) One of the compounds in petroleum gas is methane. The displayed formula of methane is shown below.

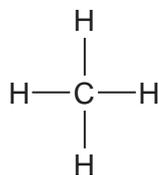

- (i) State the number of chemical bonds shown in the formula of methane.

.....[1]

- (ii) Which type of chemical bonding is found in methane?

.....[1]

- (iii) Using methane as an example, describe **one** difference between an atom and a molecule.

.....

[1]

- (b) The formula of another compound found in petroleum is shown in Fig. 2.1.

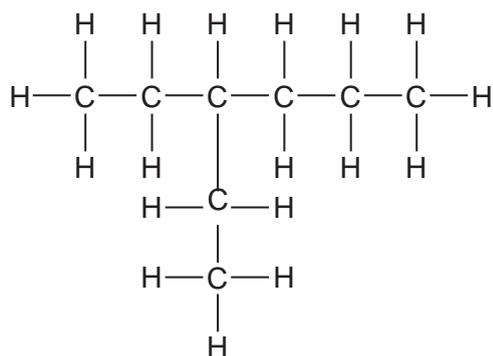

Fig. 2.1

- (i) Name the fraction in Table 2.1 in which this molecule is most likely to be found.
[1]
- (ii) Suggest **one** important use of the compound made of molecules like the one shown in Fig. 2.1.
[1]
- (c) Some of the compounds in petroleum are processed into different compounds which can then be converted into polymers. Polymers are used to make articles such as plastic bottles for drinks.
- (i) What name is given to small molecules which react to produce polymers?
[1]
- (ii) Suggest **one** advantage of using plastic rather than glass bottles for holding drinks.

[1]
- (iii) One method of disposing of unwanted plastic bottles is to burn them. A scientist studied the gases produced when a plastic bottle underwent complete combustion. She found that the only products of combustion were carbon dioxide and water.

Suggest which two elements were combined in the polymer molecules in the plastic bottles.

Explain your answer.

elements

explanation

.....

.....[3]

- 3 (a) A solid is made up of particles. In Fig. 3.1 one particle has been drawn. Draw more particles to show the arrangement of particles in a solid.

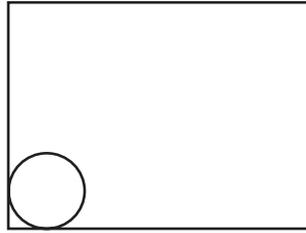

Fig. 3.1

[2]

- (b) Fig. 3.2 shows a block of solid copper.

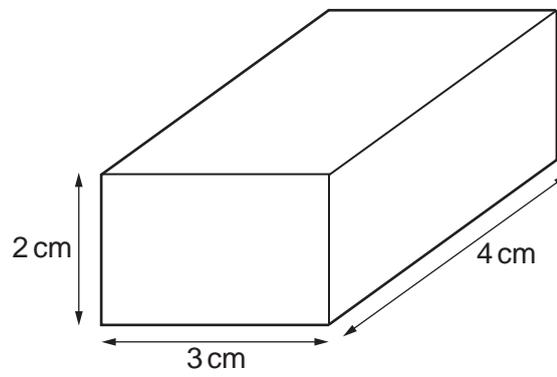

Fig. 3.2

The block has a mass of 212 g.

Calculate the density of the block using this formula.

$$\text{density} = \frac{\text{mass}}{\text{volume}}$$

Show your working and state the units of your answer.

.....[3]

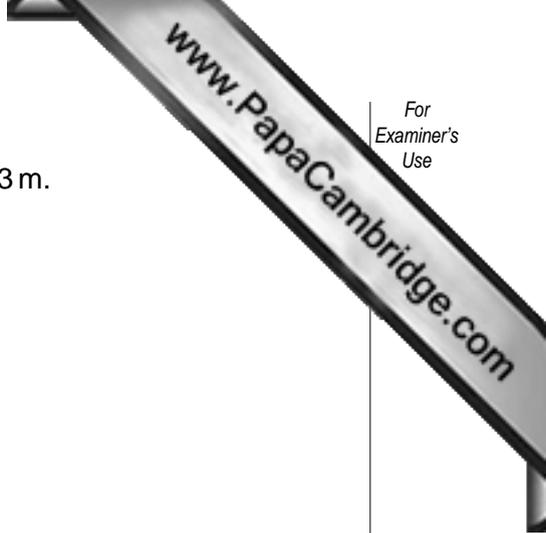

(c) The block has a weight of 2.12 N and it is raised vertically by 3 m.

Calculate the work done when raising this block.

Show your working and state the formula that you use.

formula used

working

.....J [2]

(d) After the block is raised, it has gained energy.
Which form of energy is gained?

.....[1]

4 Fig. 4.1 shows an insect-pollinated flower.



Fig. 4.1

- (a) Give the **letter** of the part of the flower which attracts insects to the flower;
- contains the female gametes.

[2]

(b) Describe how this flower could be pollinated.

.....

.....

.....

.....[3]

- (c) Apple trees are grown for their fruit. They have insect-pollinated flowers. Farmers place hives of honey bees near the trees when the trees are flowering.

Table 4.1 shows the yield of apples from a tree where a hive was placed nearby, and also from a similar tree where this was not done.

Table 4.1

tree	fruit yield / kg
hive placed nearby	23
no hive placed nearby	3

Suggest an explanation for these results.

.....
.....
.....
.....[3]

- (d) Describe how you could test an apple for the presence of reducing sugars.

.....
.....
.....[2]

- 5 The full chemical symbol for the element magnesium is shown below.



- (a) (i) Draw a diagram of one atom of magnesium showing how all of the electrons are arranged.

[2]

- (ii) Using the Periodic Table on page 20, name the element whose atoms have two **fewer** protons than a magnesium atom.

.....[1]

- (iii) Is the element you have named in (ii) reactive or unreactive?

Explain your answer.

.....
.....[1]

- (b) The list below shows some metals arranged in order of their reactivity. The element carbon has also been included.

sodium (most reactive)
 calcium
 magnesium
 aluminium
 carbon
 lead
 copper (least reactive)

A student investigates redox reactions between carbon and the oxides of some of the metals in the list. The experiments he carries out are shown in Fig. 5.1.

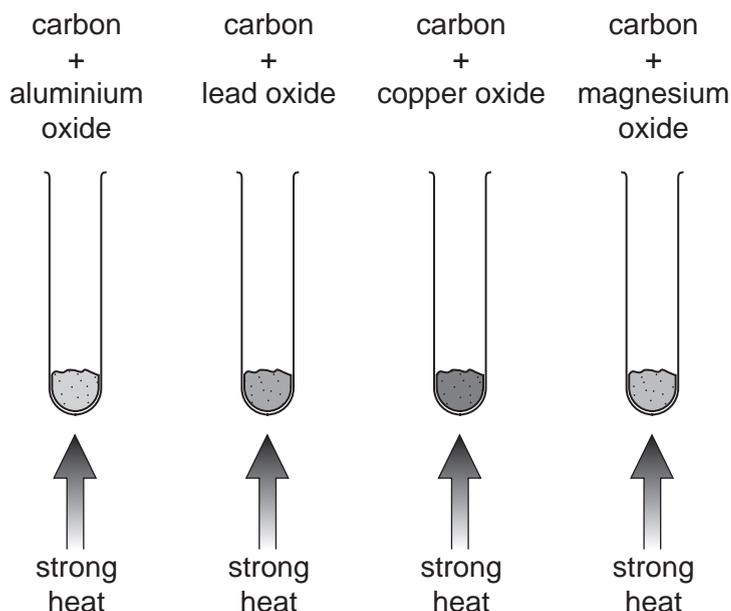

Fig. 5.1

State **two** mixtures shown in Fig. 5.1 in which the metal oxide will be reduced.

.....[1]

- (c) The metal oxides in (b) are ionic compounds.

- (i) Describe, in terms of electrons, the difference between a sodium atom and a sodium ion.

.....[1]

- (ii) Explain why the sodium ions and the oxide ions in sodium oxide bond together.

.....

[2]

- (iii) Write a word equation for the reaction in which sodium oxide is formed from sodium.

.....[1]

6 (a) A Geiger counter is used to investigate a radioactive source.

The Geiger counter is clamped in position and the count rate measured.

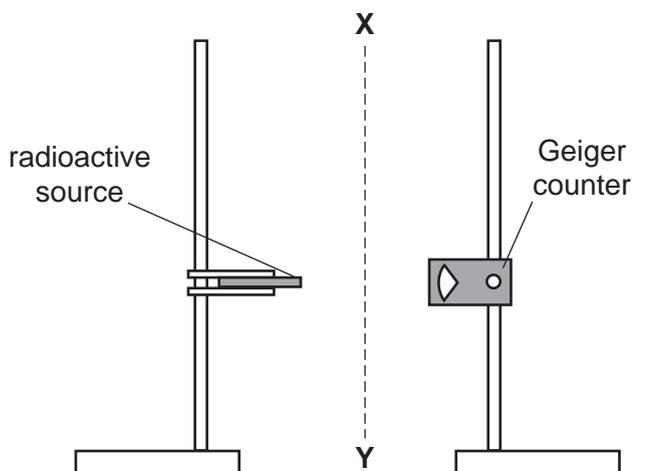

Fig. 6.1

The radioactive source is clamped facing the Geiger counter as shown in Fig. 6.1, and the count rate is measured again.

The count rate is measured twice more, once with a sheet of paper placed between X and Y and then with a 4 mm thick sheet of aluminium placed between X and Y.

The results are shown in Table 6.1.

Table 6.1

experiment		counts per minute
1	with no source present	12
2	with source only as shown in Fig. 6.1	196
3	with source and sheet of paper placed between X and Y	72
4	with source and a 4 mm thick sheet of aluminium placed between X and Y	72

(i) Explain why the Geiger counter gave a reading when no source was present.

.....
[1]

(ii) Calculate the count rate due to the source.

.....
counts per minute [1]

(iii) The count rate calculated in (ii) is **not** the total radioactivity emitted by the source.

Explain this statement.

.....
.....[1]

(iv) In experiment 3, some of the radiation emitted by the source was stopped by the sheet of paper.

Suggest the type of radiation that was stopped.

.....[1]

(v) Name the other type of radiation that is emitted by the source.

Explain your answer.

.....
.....[2]

(vi) State **one** precaution needed when handling radioactive materials.

.....[1]

(b) An atom of radon-220 decays by emitting an alpha particle.

(i) What is an alpha particle?

.....[1]

(ii) State two properties of an alpha particle.

1
2[2]

(c) Energy can be released from atoms during both nuclear fission and nuclear fusion.

Describe what happens to the nuclei of atoms during

(i) nuclear fission,[1]

(ii) nuclear fusion.
.....[1]

7 Fig trees grow in tropical rainforests. Fig trees provide food for monkeys and birds such as toucans. These animals may be eaten by eagles.

(a) (i) Construct a food web showing the feeding relationships between these four organisms.

[2]

(ii) What term is used to describe all the organisms in this food web, other than the fig trees?

.....[1]

(b) Photosynthesis takes place in the leaves of the fig trees.



Explain how photosynthesis transfers energy from sunlight into chemical energy.

.....
.....
.....[2]

(c) Describe the role of decomposers in an ecosystem such as a tropical rainforest.

.....
.....
.....[2]

(d) Tropical rainforests in many parts of the world are being destroyed by logging. Give **two** reasons why the conservation of tropical rainforests is important.

.....
.....
.....
.....[2]

- 8 (a) A student used the apparatus shown in Fig. 8.1 to study the reaction between hydrochloric acid and copper carbonate.

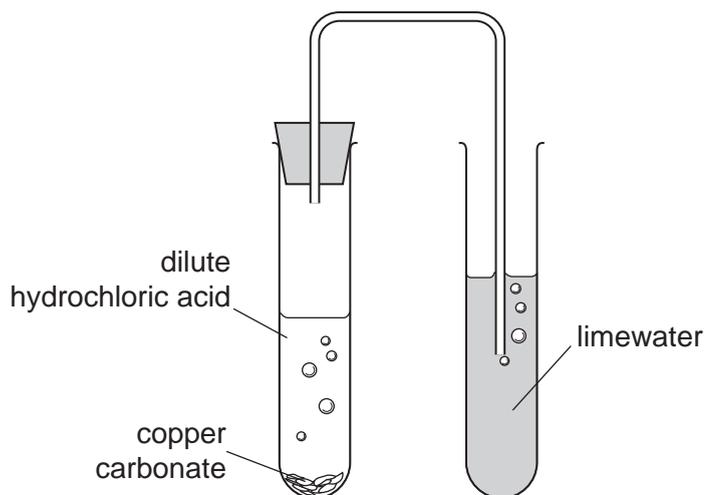

Fig. 8.1

- (i) State and explain what is observed in the test-tube containing limewater.

.....

 [2]

- (ii) Name the salt produced when dilute hydrochloric acid reacts with copper carbonate.

..... [1]

- (b) The equation below shows what happens when copper carbonate is heated.

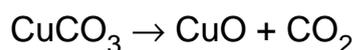

Kai-Yee describes this reaction as combustion but her friend Aysha says this is incorrect and that the reaction is an example of thermal decomposition.

Explain which student is correct.

.....

 [2]

- (c) Many carbonates, such as calcium carbonate and sodium carbonate, are white solids.

Suggest whether or not copper carbonate is also likely to be a **white** solid.

Explain your answer briefly.

.....

- 9 (a) An experiment is carried out to find out which of two teapots emits more infra-red radiation. Teapot **X** is black and dull. Teapot **Y** is silvery and shiny. The two teapots are otherwise identical.

Fig. 9.1 shows teapot **Y**.



teapot **Y**

Fig. 9.1

Both teapots are filled with the same amount of boiling water.

- (i) State two ways, other than by emitting infra-red radiation, by which energy is lost from both teapots.

1

2[2]

- (ii) The water in teapot **Y** cools more slowly than the water in teapot **X**.

Explain why this happens.

.....
[1]

- (iii) A cover made of wool or other material is often placed over a teapot to help to keep the contents hot for longer.

Explain **one** way by which the cover slows down the rate of cooling of a pot of hot water.

.....

[2]

- (b) Infra-red radiation and visible light are two regions of the electromagnetic spectrum. Name **one** other region of the electromagnetic spectrum and state a use for it.

region

DATA SHEET
The Periodic Table of the Elements

Group									
I	II	III	IV	V	VI	VII	0		
		1 H Hydrogen 1							
7 Li Lithium 4	9 Be Beryllium 4		11 B Boron 5	12 C Carbon 6	14 N Nitrogen 7	16 O Oxygen 8	19 F Fluorine 9	20 Ne Neon 10	4 He Helium 2
23 Na Sodium 12	24 Mg Magnesium 12		27 Al Aluminium 13	28 Si Silicon 14	31 P Phosphorus 15	32 S Sulphur 16	35.5 Cl Chlorine 17	40 Ar Argon 18	
39 K Potassium 20	40 Ca Calcium 20		70 Ga Gallium 31	73 Ge Germanium 32	75 As Arsenic 33	79 Se Selenium 34	80 Br Bromine 35	84 Kr Krypton 36	
85 Rb Rubidium 38	88 Sr Strontium 38		115 In Indium 49	119 Sn Tin 50	122 Sb Antimony 51	128 Te Tellurium 52	127 I Iodine 53	131 Xe Xenon 54	
133 Cs Caesium 56	137 Ba Barium 56		204 Tl Thallium 81	207 Pb Lead 82	209 Bi Bismuth 83	210 Po Polonium 84	210 At Astatine 85	210 Rn Radon 86	
Fr Francium 88	Ra Radium 88								

140 Ce Cerium 58	141 Pr Praseodymium 59	144 Nd Neodymium 60	150 Sm Samarium 62	152 Eu Europium 63	157 Gd Gadolinium 64	162 Dy Dysprosium 66	165 Ho Holmium 67	167 Er Erbium 68	169 Tm Thulium 69	173 Yb Ytterbium 70	175 Lu Lutetium 71	
232 Th Thorium 90	238 Pa Protactinium 91	238 U Uranium 92	238 Pu Plutonium 94	238 Np Neptunium 93	238 Am Americium 95	238 Cm Curium 96	238 Bk Berkelium 97	238 Cf Californium 98	238 Es Einsteinium 99	238 Fm Fermium 100	238 Md Mendelevium 101	238 No Nobelium 102

8-71 Lanthanoid series
0-103 Actinoid series

$\frac{a}{X} \frac{b}{Y}$
 a = relative atomic mass
 X = atomic symbol
 b = proton (atomic) number

The volume of one mole of any gas is 24 dm³ at room temperature and pressure (r.t.p.).